

1 . Base Frame - 1 Nos.

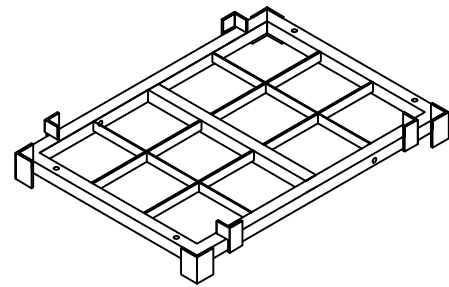

2 .1. Top Frame - 1 Nos.

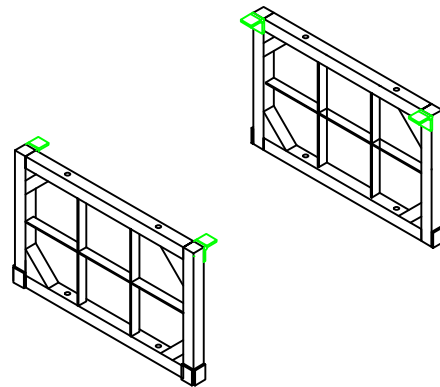

2.2 . Side Frame - 2 Nos.

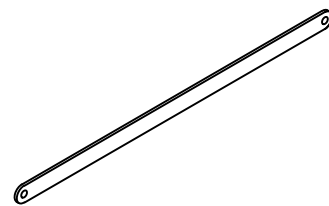

3 . Side Gussets - 2 Nos.

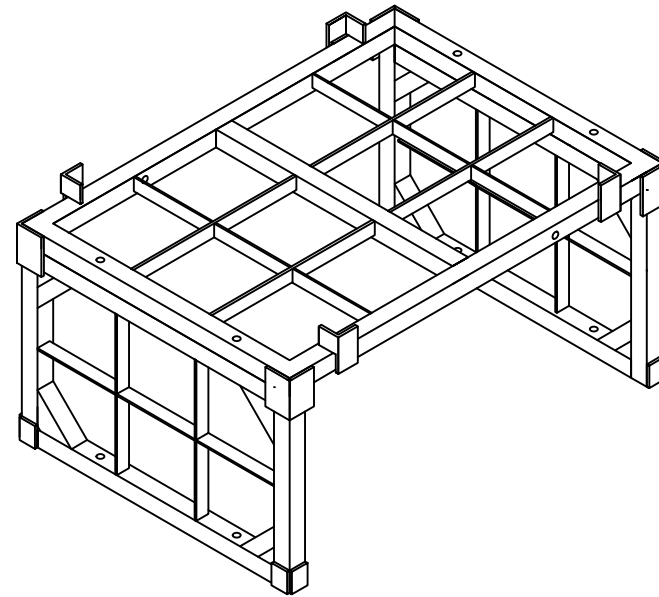

Top & Side Frame Assembly  
Isometric View

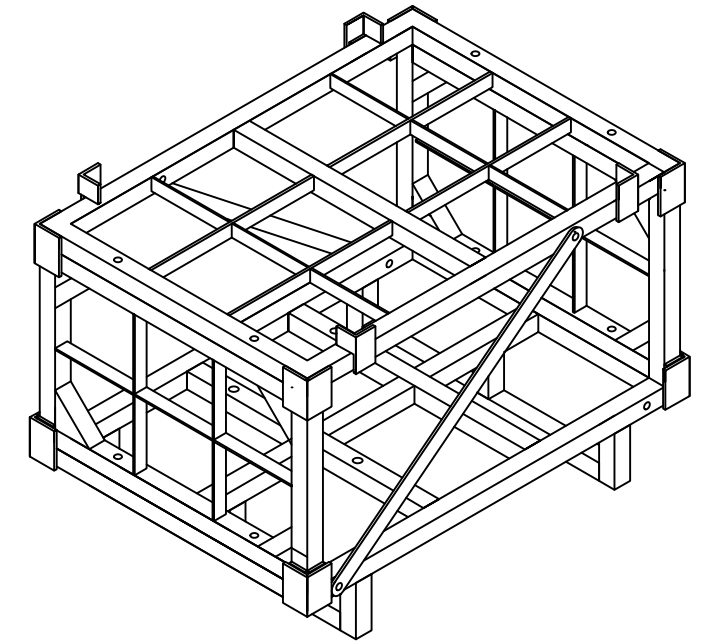

Complete Box Assembly  
Isometric View

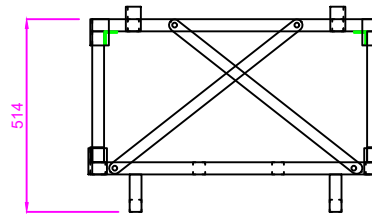

Frame in Assembled  
Condition

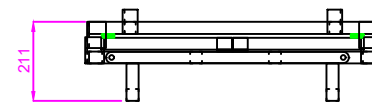

Complete Frame  
In Collapse Condition

### Motor Frame Assembly

#### Bill Of Material

Sr. No.	Material Description	Size in MM	Qty.
1	Base Frame	790 x 570 x 170	1
2.1	Top Frame	780 x 560 x 105	1
2.2	Side Frame	560 x 550 x 35	2
3	Side Gussets	648 x 5	2
4	M10 Bolt, Nut & Washer	80mm	8
5	M10 Bolt, Nut & Washer	60mm	4
6	M12 Bolt, Nut & Washer	110 mm	4

**Holisol Logistics Pvt. Ltd.**

A-1, Cariappa Marg, Sainik Farms,  
New Delhi - 110 062



DRG. NO:  
IPL/CG/MR/002

Client: CG Power & Industrial  
Solution Ltd.

DESCRIPTION

Metal Frame Top Folding - HA9400R5

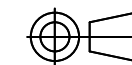

DRG. LOCATION:

QTY.

SHEET  
2 OF 2

REV. NO.

REV. DATE

SCALE:

000

000

DNS

DSNR.V. Lotankar

CKR. V. Lotankar

APPD. S. Parkar

DATE: 30.11.21

DATE: 30.11.21

DATE: 30.11.21

LET.

ALTERATIONS

DSNR.CKR. DATE

USER DEPT.

All Dimensions in MM

**A3**